

Pacific TRUCK®

P-510



**16 TONNE S.E. ASIAN
DUMP TRUCK**

**300 H.P. 6 X 4 OR 6 X 6
RIGHT HAND DRIVE**

PERFORMANCE

PAYLOAD CAPACITY	:	16.8 TONNES
VOLUME CAPACITY	:	12 C.M. APPROX.
TOTAL GEAR REDUCTION	:	77.1 TO 1
MAXIMUM SPEED	:	90 KM/H
TRACTOR TURNING RADIUS	:	11.56 M
GRADE ABILITY WITH FULL LOAD TO 5% ROLLING RESISTANCE		

LOW GEAR	56.4%	5TH GEAR	4.5%
1ST GEAR	31.5%	6TH GEAR	1.8%
2ND GEAR	20.8%	7TH GEAR	-0.1%
3RD GEAR	13.7%	8TH GEAR	-1.4%
4TH GEAR	8.6%		

WEIGHT DISTRIBUTION

CAPACITY FRONT AXLE	7,257 Kg	(16,000 lbs)	TRACTOR WEIGHT FRONT	5,684 Kg	(12,532 lbs)
CAPACITY REAR AXLE	23,586 Kg	(52,000 lbs)	TRACTOR WEIGHT REAR	8,312 Kg	(18,324 lbs)
G.C.W.	30,843 Kg	(68,000 lbs)	WEIGHT	13,996 Kg	(30,856 lbs)

PAYLOAD CAPACITY **16,847 Kg (37,144 lbs)**

DIMENSIONS

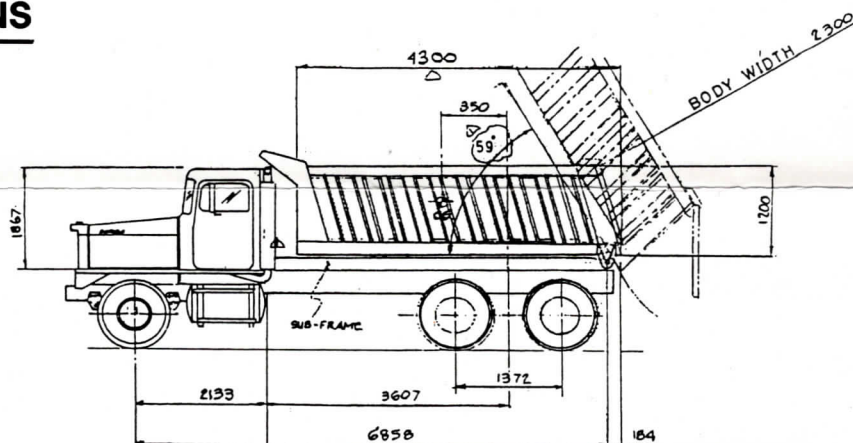

P-510

S.E. ASIAN DUMP TRUCK SPECIFICATIONS

ENGINE COMPARTMENT

Engine : 3306B turbocharged after cooled
Rated H.P. : 300 H.P. (224 kw) @ 2000 RPM
Max. Torque : 1050 lb. ft. (1424 N M) @ 1350 RPM

Air Cleaner : Single cyclopac 16 in.

Engine Brake : Jacobs brake with on/off switch

Radiator : 1000 sq. in. "ultrafuse" core
All steel construction tanks

DRIVE TRAIN

Clutch : Spicer — 14 in. two plate
Organic disc

Transmission : Fuller RT011609B 9 speed
low gear 12.56

High gear .73
Oil cooler

Transfer Case : Dama TC738 (6 x 6 only)

Drive Lines : 1710 series w/glidecoat splines

AXLES

Front Axle : Rockwell FDS 1807 Drive Axle
16000 lbs (7257 kg) capacity

Rear Axle : Rockwell RT52-180
52,000 lbs (23,586 kg) capacity
Ratio : 6.83 : 1

Differential lock on FWD axle
Suspension : Front — 15 leaf shackled style
Rear — Hendrickson RT450
— Spring suspension

WHEELS/TYRES

Spoke Wheels : 8.5 x 20 rims & spare
Lug Tyres : 12.00 x 20 18 ply & spare

CONVENTIONAL CAB

Cab : 14 GA steel welded construction
1/8 in steel tube floor and door frame
H.D. steel cab mount

Hood : 12 GA steel with center hinge
steel removable side panels

Fenders : 12 GA steel walk on style
removable for engine access

FRAME

Double Rails : 10" x 3/4" x 3/8" high tensile steel
Section Modulus : 24.90 cubic inches
R.B.M. : 42,739,000 in. lb.

CONTROL SYSTEMS

Power Steering : Dual Sheppard gear M392

Brake System : Dual circuit for safety

Park Brake : Anchorlok 30 Both rear axles

DRIVER'S AREA

Air ride drivers seat, safety glass, tilt steering wheel,
speedometer, tachometer, ammeter, oil pressure, air
pressure, fuel, water temperature gauges.

MISCELLANEOUS

300 litre steel fuel tank, high mounted
12 volt electrical system
2 x batteries 204 amp/hour
12 C.F.M. air compressor

DUMP BODY EQUIPMENT

Hyva Hoist — Single ram front of box
12 cu. mt. box H.D. steel construction
Cad operated tail gate lock
Cab protector



Pacific
TRUCK

AND TRAILER LTD.
A member of the Inchape Group

Regional Office:
989 Bukit Timah Road, Building No. 8,
Singapore 2158. Phone: 466-7610
Telex: RS 53428 Fax: (65) 466-3719