

## MODEL P - 10: STANDARD SPECIFICATIONS

### ENGINE

Cummins NTC-350 six cylinder-turbocharged  
Bore and Stroke - 5½" x 6"  
Piston Displacement - 855 cu. in.  
Brake Horsepower - 350 h.p. @ 2100 r.p.m.  
Maximum Torque - 975 lb. ft. @ 1600 r.p.m.  
Vortex Oil Bath Air Cleaner  
Water filter - spin on type  
Turner quick start  
Dana 15½" two plate clutch with clutch brake  
Vertical exhaust system with 5" dia. pipe,  
3 ft. extension, muffler guard and rain cap.

### MAIN TRANSMISSION

Spicer SST-5 1253-B  
Five speed O.D. (0.694:1 in 5th) transmission

### AUXILIARY TRANSMISSION

Spicer 1241-D (4 speed)

### DRIVE LINES

Spicer - 1710 series - front  
- 1810 series - centre  
- 1710 series - interaxle

### PARKING BRAKE

Anchorlok Double Diaphragm - Type 30  
Spring Brake Chambers on both driving axles.

### STEERING

Gemmer 500 with Vickers hydraulic power assist.

### FRONT AXLE

Rockwell Standard FL-931 with 78.4" track  
18,000 lbs. capacity  
54" load centre front springs - 4" wide  
Slipper type suspension with torque rods  
16½" x 6" brakes  
2 only 24" x 8.50 13-3/16" bolt circle disc wheels

### REAR AXLE

Rockwell Standard SFD-4640 with 81 7/8" track  
65,000 lbs. capacity  
56" axle spacing  
Pacific steel leaf suspension with 6 torque rods.  
18" x 7" brakes  
9 only 24" x 8.50, 13 3/16" bolt circle disc wheels.

### TIRES

10 only 12.00 x 24 - 16 ply nylon  
Conventional rib tread - front  
Conventional lug tread - rear

### FRAME

10" x 3¼ x 3/8" heat treated rail with 9 3/16" x 2 7/8" x 9/32" full length frame insert  
Outside frame width 34"  
Combined section modulus: 24.9 in.<sup>3</sup> per rail.  
RBM: 2,739,000 in. lb.  
Channel type bumper with centre tow pin.

### RADIATOR

Bolt on tank style - 36" high, 40" wide, 3 3/16" thick with surge tank built into top tank, thermostatically controlled air operated shutter.

### ELECTRICAL

12 volt throughout with 80 amp. - 27 si. alternator,  
6 manual reset circuit breakers,  
dual headlights, tail and stop lights.  
Cab equipment - 34,000 BTU heater, defroster fan,  
dome light, cigarette lighter.

### AIR EQUIPMENT

Schedule "L-75" single 13.5 cfm compressor with front axle control valve, low pressure indicator and air horn.

### INSTRUMENTS

Speedometer, Tachometer, Ammeter, Air Pressure Gauges, Water Temperature Gauge, Engine Oil Gauge, Fuel Gauge, Low Air Pressure Warning Light and Low Oil-High Water Warning Light.

### FUEL TANK

80 gallon capacity tank mounted on left side and equipped with non-skid flat top to serve as running board, and fuel filter.

### CAB

Pacific all steel type equipped with bulkhead type doors, safety glass throughout, fully insulated, sliding rear window, vent windows, cowl vents, Bostrom Air Viking driver's seat, Swampers seat, and dual painted West Coast Mirrors.

### HOOD & FENDERS

All steel butterfly hood with full length hinges, Grab handles and rubber hood catches.  
Fenders, removable flat top style with Non-skid top surface and mud flaps.

### PAINT

Cab - enamel single colour  
Chassis - black Rims - grey

### ACCESSORIES

Wheel wrench and handle

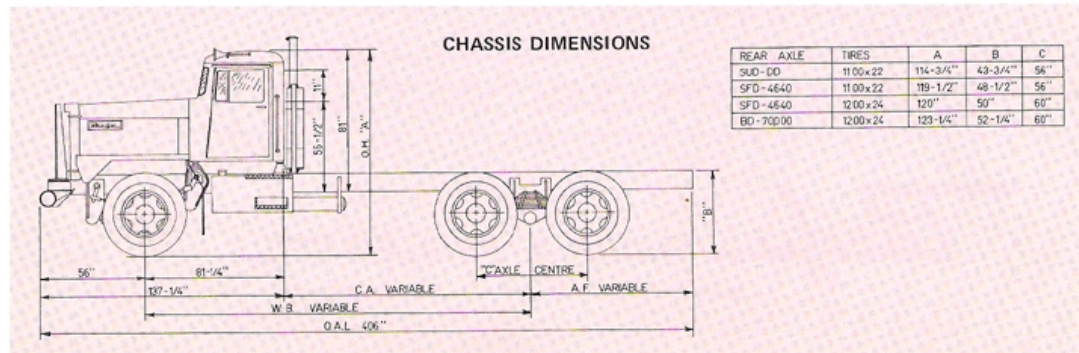

## MODEL P - 10: OPTIONAL EQUIPMENT

### ENGINE

Detroit Diesel 8-V-71-T (350 h.p.)  
Detroit Diesel 12-V-71  
Cummins NTA-400 (400 h.p.)  
Block Heater  
Exhaust pyrometer  
Jacobs brake  
Theromatic fan.

### MAIN TRANSMISSION

Spicer SST-1263-A (6 speed)  
Bottom mount P.T.O. for Spicer 1253 or 1263 Transmission  
Allison CLBT 5860 (must use 40" frame)  
Allison CLBT 5960 (with 12-V-71 and 40" frame)

### AUXILIARY TRANSMISSION

Spicer 1241-C  
Top mounted P.T.O.

### DRIVE LINES

1810 series driveline mandatory with Engine 360 h.p. or over.

### AIR BRAKES

2 compressor system  
Alcohol evaporator

### PARKING BRAKE

Maxi on both driving axles.

### FRONT AXLES

Shuler DCA-34 18,000# axle with 90" track  
(mandatory with 40" frame)

### REAR AXLES

Clark BD 71,000 with 90" track, 20" x 7"  
brakes, 24" x 10" spoke wheels, type 36 AC  
Steering Yoke from forward housing to centre  
trunnion, 60" axle spacing.

Steering Yoke from forward housing to centre  
trunnion.

### TIRES

12.00 x 24 - 16 ply hard rock lug extra tread nylon  
14.00 x 24 - 20 ply hard rock lug or rib nylon with  
shredded wire undertread.  
14.00 x 24 - 20 ply hard rock lug extra tread nylon  
with shredded wire undertread.  
24" x 10" wheels (47820-D2) in lieu of 24" x 8½" wheels.  
Spare tires of same size and type as listed above.

### FRAME

40" frame for use with Allison CLBT 5860,  
Allison CLBT 5960, and Shuler DCA-34 front axle.  
Dump insert  
Grille Guard

### ELECTRICAL

Turn indicators  
Clearance lights - 2 cab mounted  
Driving light mounted below bumper  
Back up light.  
Trailer Connection (7 way)  
Flasher warning lights mounted on mirrors  
24 volt, 75 amp. - 25 SI alternator  
12 volt, 75 amp. - 25 SI alternator

### INSTRUMENTS

Transmission temperature gauges  
Axle temperature gauges  
Windshield washer  
Tachograph  
Speedograph  
34,000 BTU heater in lieu of or in addition to  
17,500 BTU heater.

### FUEL

85 gallon capacity tank mounted on front of  
water tank.

### CAB AND ACCESSORIES

Fire extinguisher - 2½ lbs. dry type  
Set of two reflector flares and flags  
Sun visor  
Spring loaded mudflaps  
Hydraulic Jack (12 and 20 ton cap.)

### LOGGING EQUIPMENT

400 gallon water tank, water lines and  
controls in cab  
Conventional bolster w/sub frame and trailer  
rests  
Circular bolster w/sub frame and trailer rests  
Cab Protector  
Oil bath type compensator SP-290 Premier  
hitch and latch type reach lock  
Funnel type hitch in lieu of Premier hitch  
Self-load equipment

---

In order that product improvements may be introduced at any time specifications are subject to change without notice.

---

These specifications are of a standard nature, but owing to our ability to custom build all our trucks, specifications may be made to suit individuals with the approval of Engineering Department.

---

 **Pacific TRUCK & TRAILER LTD.**

935 West 3rd Avenue • North Vancouver, British Columbia • Telephone (604) 985-7121